

LAN Distance Limitations

- LAN technologies are designed with constraints of speed, distance, and cost.
- A typical LAN technology can span, at most, a few hundred meters. LANs are not designed for long distances.
- The need for fair access on shared media such as Ethernet and token ring limits the size of a LAN.
 - CSMA/CD doesn't work satisfactorily when a network gets too big.
 - Neither does token passing.

LAN Distance Limitations

- Signal strength and noise become serious problems over long distances.
- How can a LAN be extended to cover larger distances such as the Gettysburg campus?
- Let's see.

LAN Extensions

- Several techniques extend the effective size of a LAN medium.
- Most techniques use additional hardware.
- LAN signals are relayed between LAN segments.
- The resulting mixed technology stays within original engineering constraints while spanning greater distances.

Fiber Optic Extensions

- Fiber optic cable can be used to extend a connection to a computer on a LAN.
- On Ethernet, fiber optic cable and two fiber modems are inserted into the AUI cable.
- This technique does not involve changing the original LAN and works over distances of several kilometers.

Repeaters

- repeater - a bidirectional analog amplifier that amplifies and retransmits signals.
- A repeater can be used to extend the size of a LAN medium.
- One repeater can effectively double the length of a LAN segment.

Example: An Ethernet repeater can double the maximum size of an Ethernet segment from 500 meters to 1000 meters.

- Ethernet can't be extended indefinitely with repeaters. CSMA/CD requires low delay and won't work on a long medium.

Repeaters

- The Ethernet standard includes a limit of 4 repeaters between any 2 stations.

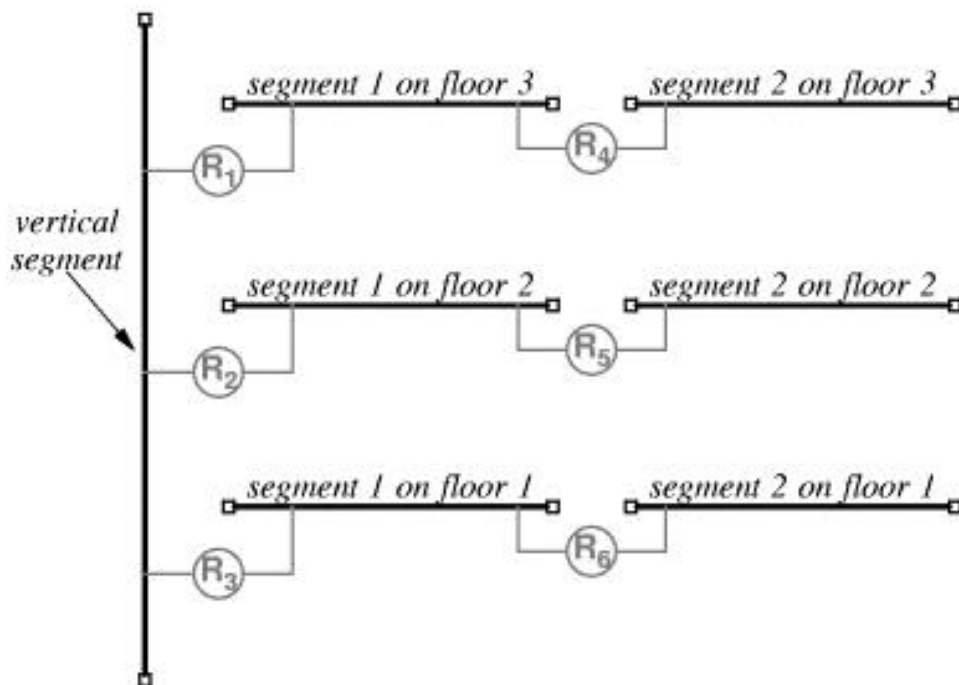

Characteristics of Repeaters

- Repeaters are very easy to use. Just plug them in and they're ready to go.
- Repeaters simply retransmit signals between segments.
- Repeaters don't understand frame formats.
- Repeaters don't have hardware addresses.
- Collisions affect the entire extended network.
- Noise propagates throughout the extended network.

Bridges

- bridge - a hardware device that connects two LAN segments and copies frames from one to the other.
- Like a repeater, a bridge connects two LAN segments.
- Unlike a repeater, a bridge understands and retransmits complete frames.
 - Uses a NIC like any other station.
 - Can perform additional frame processing.
- A bridge is invisible to other attached computers.

Characteristics of Bridges

- Bridges are relatively easy to use.
- Bridges isolate collisions and noise.
- Bridges perform frame filtering.

Frame Filtering

- In addition to not forwarding collisions and noise, bridges perform frame filtering. They forward frames only as necessary.
 - A bridge knows the location of each computer.
 - When it receives a frame, it checks the destination address.
 - If the destination computer is on the same segment, the frame is not forwarded.
 - If the destination computer is on the other segment, the frame is forwarded.
 - Broadcast and multicast frames are always forwarded.

How Does a Bridge Learn?

- Most bridges learn which computers are attached to which segment.
- Initially, a bridge doesn't know anything about the locations of attached computers and its forwarding table is empty.
- Once a computer sends a frame, a bridge reads the source address and learns the computer's segment. The information is added to the bridge's forwarding table.
- As more computers transmit, the bridge learns more computer locations.

How Does a Bridge Learn?

- Until a bridge knows a computer's location, it has to forward any frames intended for that computer.
- Once a bridge knows a computer's location, it forwards only as necessary.
- Initially, there's a lot of forwarding. As a bridge learns, forwarding is done only as needed.
- If a power failure occurs, a bridge's forwarding table is wiped out. When power is resumed, a burst of traffic can occur.

Designing a Bridged Network

- A filtering bridge allows concurrent use of different LAN segments provided the traffic is local.
- Designers identify patterns of local usage and isolate groups of frequently communicating computers with bridges.
- Bridges can also be used to connect two LAN segments in different buildings.
- Bridges can even be used with leased-line, microwave, laser, and satellite to connect two LAN segments.

Bridges and Cycles

- Several bridges can be used to connect many LAN segments.
- A station on segment c transmits to a station on segment g through bridges B_2 , B_1 , B_3 , and B_6 .
- Broadcast frames are forwarded by all bridges.
- Question: What happens if another bridge connects segments f and g?
- The result is a cycle. If all bridges are allowed to forward all frames, an increasing number of frame copies can loop indefinitely.

Bridges and Cycles

- To prevent infinite looping when a bridged network contains cycles, some bridges must not be allowed to forward all frames.
 - Easy for a small bridged network.
 - Hard for a large bridged network.
 - What if a bridge fails or a new bridge is added? How are things updated?

Bridges and Cycles

- The solution uses the notion of a spanning tree from graph theory.
 - Bridges communicate with each other to determine a spanning tree. There's actually a spanning tree protocol.
 - Once a spanning tree is determined, bridges disconnect appropriate interfaces.
 - With the interfaces disconnected, loops are removed and frames cannot cycle.
 - If a link fails or a new bridge is added, the bridges reconnect all interfaces and run the spanning tree algorithm again.

Switches

- switch - an electronic device that forms the center of a star topology network and uses the destination address in a frame to determine where to forward the frame.
- Physically, a switch resembles a hub.
- Unlike a hub which forwards what it receives to each computer, a switch forwards a frame only to the destination computer.
- A hub simulates a single segment shared by all computers. Only two computers can communicate at a time.

Switches

- A switch allows each computer to think it's on a segment by itself.
- Thus, as many as half the computers can send at a time if they're sending to the other half. Higher bandwidth.
- Essentially, switches are high-performance multi-interface bridges.
- The main difference between a bridge and a switch is that bridges usually have a small number of interfaces (2-4) whereas switches may have dozens of interfaces.

Bridges vs Routers

- What's the difference between a bridge and a router?
- router - a hardware device that connects two or more networks and forwards packets according to information in its routing table.
- bridge - a hardware device that connects two LAN segments and copies frames from one to the other.
- Both routers and bridges are store-and-forward devices. Both receive entire packets, store them in a queue, and forward them.

Bridges vs Routers

- Both routers and bridges are candidates for interconnection devices, but there is a fundamental difference.
 - A bridge forwards packets using hardware or physical addresses. That is, a bridge is a layer 2 packet switch.
 - A router forwards packets using IP addresses. That is, a router is a layer 3 packet switch.